



Initiative Integrity Innovation

Zhejiang Hechuan Technology Co.,Ltd.

Headquarters: No. 5, Qinshan Road, Longyou Industrial Park, Quzhou City, Zhejiang Province
Hangzhou R & D Center: No. 299 Lixin Road, Qingshanhu Street, Hangzhou City, Zhejiang Province



YOUTUBE



LinkedIn

All information in this document is subject to change without notice.
Manual No.May, 2026 Issue No. 1
Due to the delay in updating the paper version, please refer to the official website for the latest product information.

EtherCAT® is owned by Beckhoff Automation GmbH; MECHATROLINK® is owned by MECHATROLINK Association, which is an open field network; PROFINET is a new Ethernet communication system developed by Siemens and PROFIBUS User Association. Other products, product names, trademarks or registered trademarks of the products belong to the respective companies and are not our products

X5-SERVO

Advanced AC Servo Drive Catalog

EtherCAT

PROFINET

CANopen



Rich choices and easy to use

**Meet the industry demand
for ultimate cost-effectiveness in
the general market**

X5-SERVO





Rich motion control bus

The X5 series advanced servo system uses self-developed chips. In addition to EtherCAT communication method, it also supports CANopen and PROFINET communication, and can be flexibly matched with various control systems.



Easy to use!

Single parameter adjustment gain and two sets of adaptive notches can greatly shorten debugging time! The pulse full-functional models have full closed-loop function and gantry synchronization function.



Safe and reliable!

All series are equipped with the DB (Dynamic Brake) function as standard, and the full-function models are equipped with the STO (Safe Torque Off), which can protect the safety of people and machines when danger occurs.



Naming rules

SV-X5 E B 040 A - A 0 - 00

1 2 3 4 5 6 7 8

1 Product series

2 Models

E	Standard type
F	Full-functional type

3 Control type

A	Pulse
B	EtherCAT
N	CANopen
R	PROFINET

4 Power

010	100W
040	400W
075	750W
100	1KW
150	1.5KW
200	2KW
250	2.5KW
300	3.0KW
500	5.0KW
750	7.5KW

5 Voltage type

A	220V
T	380V

6 Control power type

A	AC
---	----

7 Version iteration

0	By default
---	------------

8 Hardware identification

00	By default
CO	EB/FB frequency division models (customized)
GS	FA gantry co-drive models (customized)

• **AC220V** 100W 2.5KW

• **AC380V** 2KW 3KW 7.5KW

Rich motion control bus

Adopting self-developed chips, in addition to EtherCAT communication method, the X5 series advanced servo system also supports CANOPEN and PROFINET communication, and can be flexibly matched with various control systems.



EtherCAT®

PROFI®
NET

CANopen®

X5 FR PROFINET bus servo

Meet the market demand for **PROFINET** bus ecology



- Adopt Siemens ERTEC200P special chip solution
- With a wider range of power and motor models to choose from
- With higher control accuracy, up to 23BIT resolution
- Various message selections enable various control methods

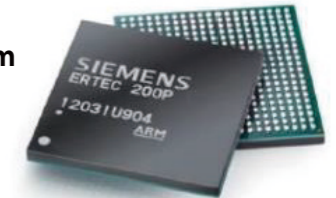

Message	Standard message1	Standard message2	Standard message3	Siemens message102	Siemens message105	Siemens message110	Siemens message111	Siemens message750
Supported or not	✓	-	✓	✓	✓	-	✓	✓

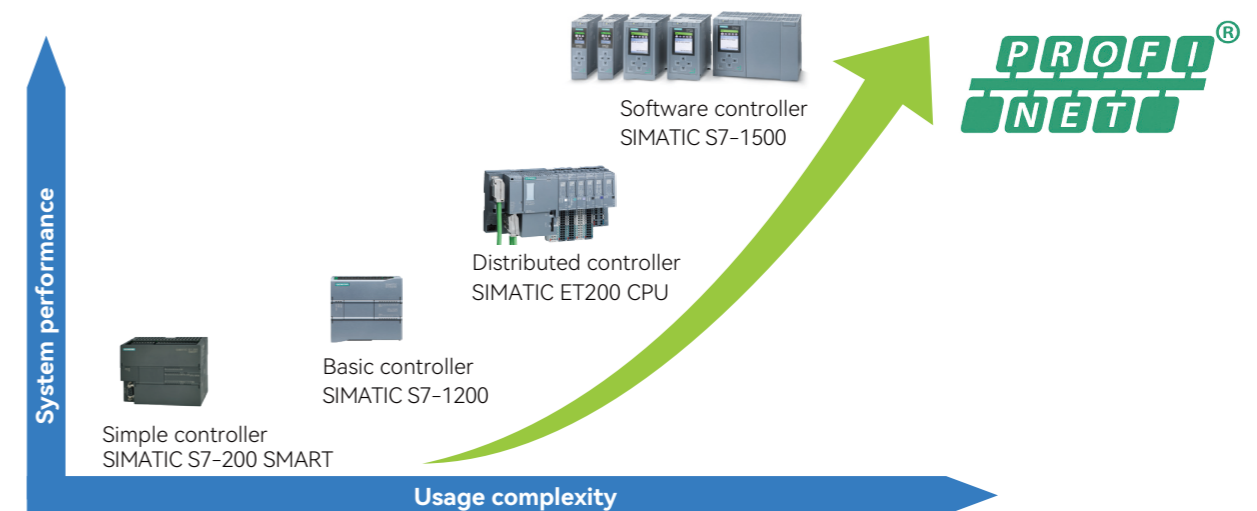

- Complying with the standard PROFIDRIVE profile, whether it is simple single-axis control or complex multi-axis synchronous motion control, the X5PN series can be perfectly adapted to Siemens PN bus PLCs such as S7-200 Smart, S7-1200, S7-1500 and Simotion .
- Smaller synchronization period, the minimum synchronization period reaches 500us, achieving precise servo process control.

Transmission distance	Real time communication	Isochronous communication	Synchronization period
100 m	RT	IRT	500 μ s

Quick debugging Easy to use

Online inertia identification

During the operation of the equipment, you can check the real-time inertia of the equipment through the parameters (P21.11), and then adjust the inertia parameters to complete the setting of the equipment inertia and achieve rapid machine adjustment.

Single parameter adjustment gain

Through the setting of the rigidity level selection function (P00.03 0~31), different levels of servo response adjustment can be realized , which is simple and easy to use and shortens the debugging time of the equipment.

Notch filter

There are four sets of notch filters, including two sets of built-in automatic filters. When turned on (P02.02), the resonance frequency and resonance depth can be automatically captured to eliminate equipment resonance and improve the responsiveness of the equipment.

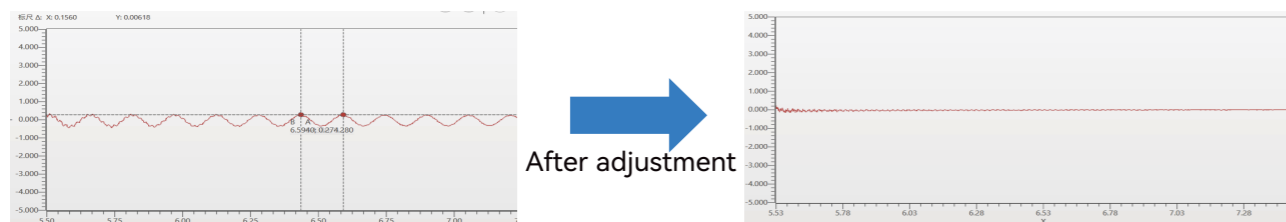

Full closed loop function

The pulse full-function FA model has a full closed loop function . When combined with a digital grating scale, it can effectively eliminate position deviations caused by mechanical gaps and improve the positioning accuracy of the equipment.

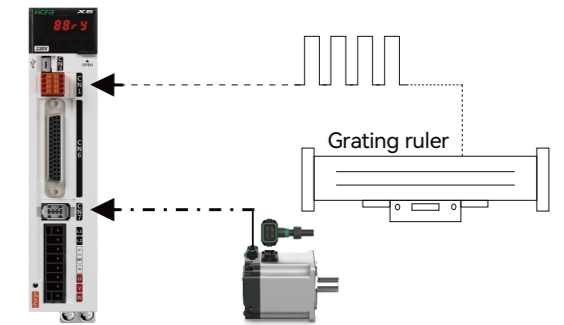
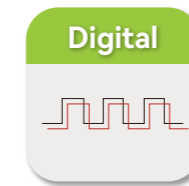

Gantry synchronization function

The pulse-type FA gantry special machine model has a gantry synchronization function. The gantry dual drive shaft interacts with the real-time position of the motor to prevent beam distortion, improve equipment stability, and effectively improve processing accuracy.

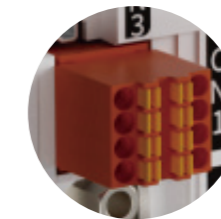
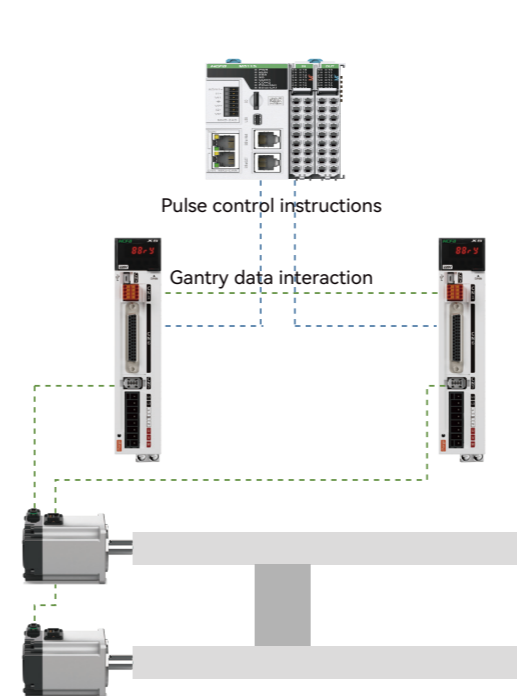

Name	Signal name	Description
CN1 Second encoder port	5V	Grating ruler power supply
	GND	
	A+	Maximum frequency of parallel signal reception: 5M (after frequency×4)
	A-	
	B+	
	B-	
PE	Signal cable shielding layer	

Safe and reliable Optimized design

DB (Dynamic Brake)

The whole series are equipped with a dynamic braking function as standard, which can quickly stop servo motor when power failure or alarm occurs while the motor is running, thereby protecting the safety of people and equipment.

STO (Safe Torque Off)

When a danger occurs, the torque cut-off function of the servo is triggered, and the internal hardware circuit of the servo will be triggered to forcibly shut down the drive, disconnect the power supply to the motor, and stop the motor from running to protect personal and equipment safety.

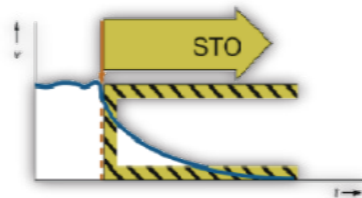

Strengthened EMC protection

The overload capacity, EMC leakage and overall servo protection have been improved by 30%, making the equipment operation more reliable and stable.



Note: EMC leakage current control takes 750W as an example. X3E series is at about 1.5-2mA while X5 series is at 0.5mA.

Optimized structural design

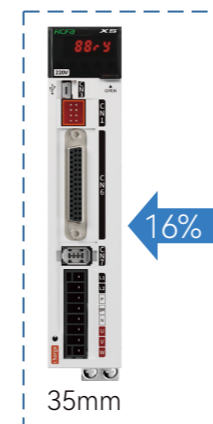

X5 series optimizes the structural design. Taking the 400W model as an example, compared with the previous generation product, the body width is reduced by **16%**, reducing the installation space.

While ensuring a compact body, the independent air duct design can prevent dust, high humidity and other foreign matter from invading the drive body, effectively improving product reliability!



■ Environmental specifications

Items		Specifications
Temperature	Ambient temperature for use	0~55°C
	Ambient temperature for storage	-20~65°C
Humidity	Ambient humidity for use	20~80%RH or less (no condensation)
	Ambient humidity for storage	20~80%RH or less (no condensation)
Environment		Indoors (no direct sunlight), no corrosive gases, flammable gases, oil mist or dust
Altitude		1000m or less. Please derate when above 1000m.
Vibration		5.8m/s ² (0.6G) or below, 10 ~ 60Hz (Avoid being used continuously at the resonance frequency)
Insulation withstand voltage		Between primary and FG, 1500VAC for 1 minute

■ Specification configuration

Funcitons		Pulse		EtherCAT bus		CanOpen bus	PROFINET bus
		Full-functional FA	Standard EA	Full-functional FB	Standard EB	Standard EN	Full-functional FR
Hardware interface	CN1 second encoder	✓	-	-	-	-	-
	CN2 STO	✓	-	✓	-	-	✓
	CN4/CN5 communication	RS485	RS485	EtherCAT	EtherCAT	RS485/CANopen	PROFINET
	CN6 I/O interface	44pin	44pin	15pin	15pin	44pin	15pin
Hardware functions	PC communication	USB/RS485	USB/RS485	USB	USB	USB	USB
	Number of I/Os	8DI/5DO	8DI/5DO	5DI/3DO	5DI/3DO	8DI/5DO	5DI/3DO
	Analog input	2AI	2AI	-	-	-	-
	Analog output	-	-	-	-	-	-
	Pulse frequency division output	✓	✓	FB-CO/EB-CO supported	FB-CO/EB-CO supported	✓	-
	Dynamic braking	✓	✓	✓	✓	✓	✓
Software functions	Full closed-loop function	✓	-	-	-	-	-
	Gantry synchronization	FA-GS supported	-	-	-	-	-
	Internal positioning	✓	✓	-	-	✓	-

■ Technical specifications

Items		Specifications
Control method		control
Control modes		9 control modes: Position control, speed control, torque control, position/speed control, position /torque control, speed/torque control, CANOpen bus mode, EtherCAT bus mode, PROFINET bus mode
Common functions	Adaptive notch filter	4 notches, 100Hz-5000Hz, two adaptive recognition
	Adjustment /function setting	By setting software [HCS-Studio] for adjustment
	Protection function	Overvoltage, power supply error, overcurrent, high temperature error, overload, encoder error, overspeed, excessive position deviation, parameter error
	STO function	Input /output signal
	Encoder feedback	First encoder
Second encoder		Supports ABZ grating ruler and magnetic band ruler

■ Technical specifications

Items		Specifications	
Position control	Control input	8 inputs (24VDC optocoupler isolation), switch according to configuration information Servo ON, alarm reset, deviation counter clear, positive overtravel, negative overtravel, command input inversion, internal command selection input 1, internal command selection input 2, internal command selection input 3, internal command selection input 4, internal Position command nabled input, origin position input	
	Control output	5 outputs (24VDC optocoupler isolation, open collector output) switch according to configuration information Alarm status, servo-ready, brake release, torque limit output, position proximity, position arrival, origin return completion, motor rotation output, zero-speed signal output	
	Pulse input	Maximum command pulse frequency	Differential pulse input: Frequency not more than 4MHz, pulse width larger than 125ns Open collector: Frequency not more than 200kHz, pulse width larger than 2.5us
		Input pulse signal form	2-ch differential inputs; 2-ch open collector inputs (compatible with NPN and PNP)
		Input pulse signal mode	Pulse + direction, orthogonal phase difference (A phase + B phase), CW + CCW pulse
		Electronic gear setting	A/B A : 1 ~ 1073741824 B : 1 ~ 1073741824, Encoder resolution /10000000 < A/B <Encoder resolution/2.5
	Command filter	Smoothing filter, FIR filter	
	Pulse output	Output pulse form	Phase A, Phase B: RS-422 differential output Z phase: RS-422 differential output or 24V open collector output Applicable to FA/EA/FB-CO/EB-CO/EN models
		Frequency division	Any(max. 131071)
		Output pulse function	Encoder position pulse and position pulse command (can be set)
Gantry synchronization function		Use the second encoder interface for gantry synchronization	
Speed control	Control input	8 inputs (24VDC optocoupler isolation), switch according to configuration information Servo-ON, alarm reset, speed command reverse, zero-speed clamp, internal command selection input 1, internal command selection input 2, internal command selection input 3, internal command selection input 4, forward external torque limit input, reverse rotation External torque limit input, emergency stop	
	Control output	5 outputs (24VDC optocoupler isolation, open collector output) switch according to configuration information Alarm status, servo-ready, brake release, torque limit output, speed limit output, speed reach, speed consistency, motor rotation output, zero-speed signal output	
	Analog input	Speed command input	Input voltage -10V ~ +10V (maximum speed at ±10V)
		Torque limit command input	1) Forward and reverse internal torque limits, factory default settings, set the forward and reverse torque limit values respectively by P03.09 and P03.10. 2) Forward and reverse external torque limits, set the forward and reverse torque limit values respectively by P03.11 and P03.12. Then use the DI functions P_CL and N_CL to select whether the forward and reverse restrictions are in effect. 3) 2-TLMT is used as the forward and reverse torque limit, that is, the AI1 or AI2 input is used as the forward and reverse limit values at the same time. 4) 3-TLMT and TLMTN forward and reverse limits, that is, AI1 and AI2 inputs are used as forward and reverse limit values respectively.
		Torque feedforward command input	1) Internal torque feedforward 2) Use TFFD as torque feedforward input, that is, use the AI1 or AI2 input value as torque feedforward.
		Internal speed command	Use DI terminal signal combination to achieve stage 0~16 speed selection
	Analog signal input	2 inputs (±10V), switch according to control mode	

■ 220V AC basic specifications

Items		Specifications 220V						
Models SV-X5E□***A-A0-00 Note1		010	040	075	100	150	200	250
Power(W)		100	400	750	1000	1500	2000	2500
Rated current(Arms)		1.2	3	4.5	6	10	12.5	15.6
Max. output current(Arms)		3.6	9	13.5	18	30	37.5	37.5
Power Specifications		Single-phase 200~240V 50~60Hz				Three-phase 200~240V 50~60Hz		
Standard regenerative resistor	Resistance(Ω)	-	-	-	-	40	40	40
	Capacity(W)	-	-	-	-	100	100	100
External regeneration resistor	Resistance(Ω)	≥45	≥45	≥40	≥40	≥30	≥30	≥30
Overvoltage level		III						

Note: □ indicates the control type, A is pulse type, B is EtherCAT, N is CANopen, R is PROFINET.

■ 220V AC servo drive model specification

Power(KW)	Pulse	EtherCAT	CANopen	PROFINET	Power supply	Control power
0.1	SV-X5□A010A-A0-00	SV-X5□B010A-A0-00	SV-X5EN010A-A0-00	SV-X5FR010A-A0-00	Single-phase 220VAC	Shared main circuit power supply
0.4	SV-X5□A040A-A0-00	SV-X5□B040A-A0-00	SV-X5EN040A-A0-00	SV-X5FR040A-A0-00		
0.75	SV-X5□A075A-A0-00	SV-X5□B075A-A0-00	SV-X5EN075A-A0-00	SV-X5FR075A-A0-00		
1	SV-X5□A100A-A0-00	SV-X5□B100A-A0-00	SV-X5EN100A-A0-00	SV-X5FR100A-A0-00		
1.5	SV-X5□A150A-A0-00	SV-X5□B150A-A0-00	SV-X5EN150A-A0-00	SV-X5FR150A-A0-00	Three-phase 220VAC	AC220V
2	SV-X5□A200A-A0-00	SV-X5□B200A-A0-00	SV-X5EN200A-A0-00	SV-X5FR200A-A0-00		
2.5	SV-X5□A250A-A0-00	SV-X5□B250A-A0-00	SV-X5EN250A-A0-00	SV-X5FR250A-A0-00		

Note: E in □ is the standard type and F is the full-function type.

■ 380V AC basic specifications

Items		Specifications 380V			
Models SV-X5E□***T-A0-00		200	300	500	750
Power(W)		2000	3000	5000	7500
Rated current(Arms)		9	12	17	26
Max. output current(Arms)		17	24	42.5	65
Power Specifications		Three-phase 323~440V 50~60Hz			
Standard regenerative resistor	Resistance(Ω)	50	50	35	35
	Capacity(W)	80	80	100	100
External regeneration resistor	Resistance(Ω)	45	40	35	25
Overvoltage level		III			

Note: □ indicates the control type, A is pulse type, B is EtherCAT, N is CANopen, R is PROFINET.

■ 380V AC servo drive model specification

Power(KW)	Pulse	EtherCAT	CANopen	PROFINET	Power supply	Control power
2	SV-X5□A200T-A0-00	SV-X5□B200T-A0-00	SV-X5EN200T-A0-00	SV-X5FR200T-A0-00	AC three-phase 380V	AC380V
3	SV-X5□A300T-A0-00	SV-X5□B300T-A0-00	SV-X5EN300T-A0-00	SV-X5FR300T-A0-00		
5	SV-X5□A500T-A0-00	SV-X5□B500T-A0-00	SV-X5EN500T-A0-00	SV-X5FR500T-A0-00		
7.5	SV-X5□A750T-A0-00	SV-X5□B750T-A0-00	SV-X5EN750T-A0-00	SV-X5FR750T-A0-00		

Note: E in □ is the standard type and F is the full-function type.

Models of 100W-1KW



Circuit breaker

Used to protect the power supply circuit and cut off the power supply in case of overcurrent.

Noise filter

Used to suppress noise from the power supply.

Magnetic contactor

Turn on/off the servo power supply. Please install surge absorber when using.

Main power supply 220V AC

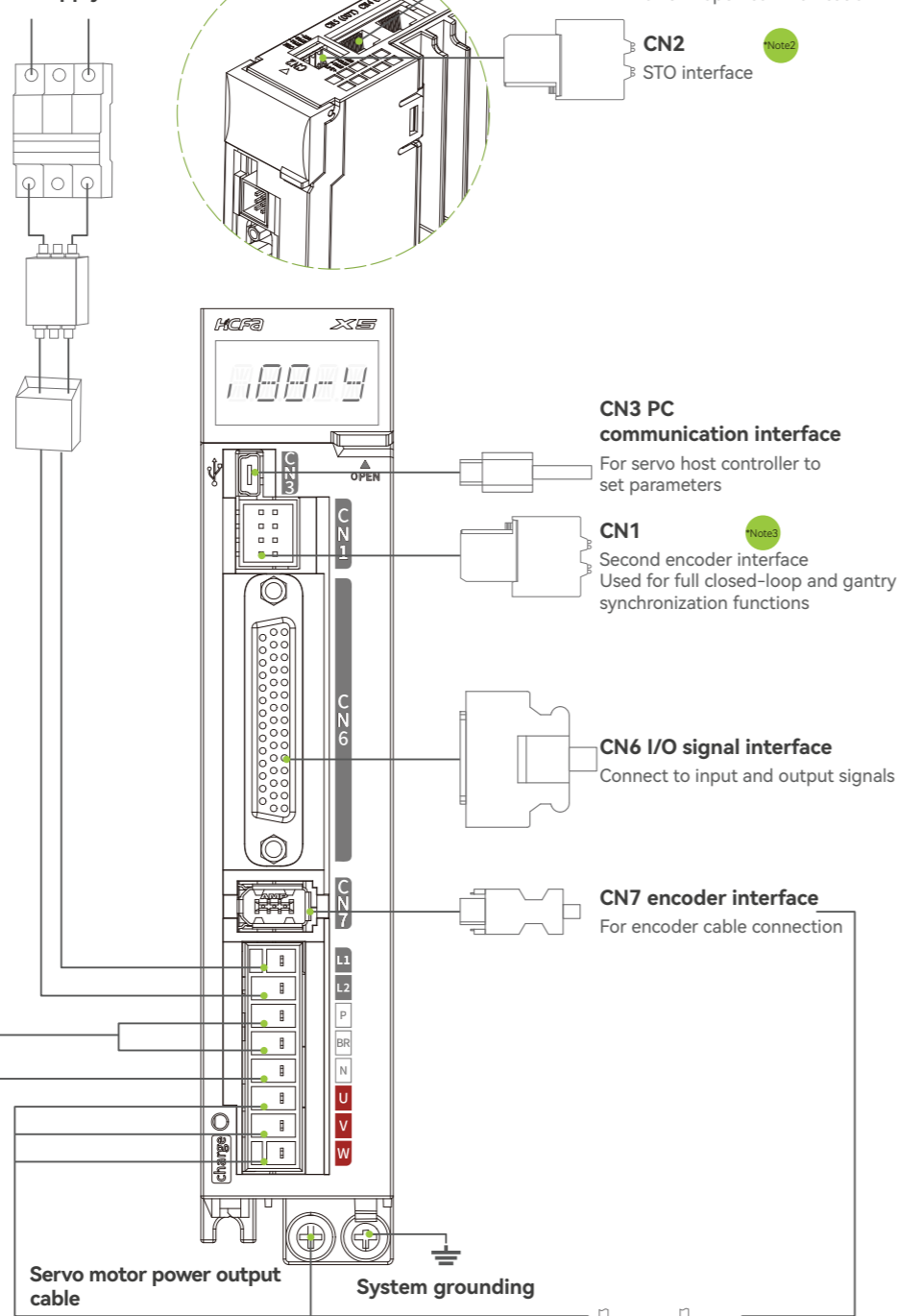

CN4/CN5 communication interface
Used for RS485 communication, or CANopen communication

CN2 STO interface

CN3 PC communication interface
For servo host controller to set parameters

CN1 Second encoder interface
Used for full closed-loop and gantry synchronization functions

CN6 I/O signal interface
Connect to input and output signals

CN7 encoder interface
For encoder cable connection

L1/L2 AC main power input

P/BR External regeneration resistor connection

N Bus negative pole

U/V/W interface
Motor power output interface
For connection to servo motors

Servo motor power output cable

System grounding

CN1 connector	No.	Signal name	Description
	1	5V	Grating ruler power
	2	GND	
	3	A+	Parallel signal
	4	A-	Max. receiving frequency: 5M (after frequency×4)
	5	B-	
	6	B-	
	7	PE	Signal cable shielding layer
	8	NC	-

CN2 connector	No.	Signal name	Description
	1	STO_OUT+	Output+
	2	STO_OUT-	Output-
	3	STO2+	Input2+
	4	STO2-	Input2-
	5	STO1+	Input1+
	6	STO1-	Input1-
	7	24V	Internal 24V port
	8	COM	

Models of 1.5KW-2.5KW



Circuit breaker

Used to protect the power supply circuit and cut off the power supply in case of overcurrent.

Noise filter

Used to suppress noise from the power supply.

Magnetic contactor

Turn on/off the servo power supply. Please install surge absorber when using.

L1C/L2C

AC control power input

L1/L2/L3

AC main power input

Internal regeneration resistor interface (P/C)

Short-circuit P/C and connect the built-in regenerative resistor

External regeneration resistor interface (P/D)

Disconnect P/C and connect an external regenerative resistor between P/D

N Bus negative pole

U/V/W interface

Motor power output interface
For connection to servo motors

Main power supply 220V AC

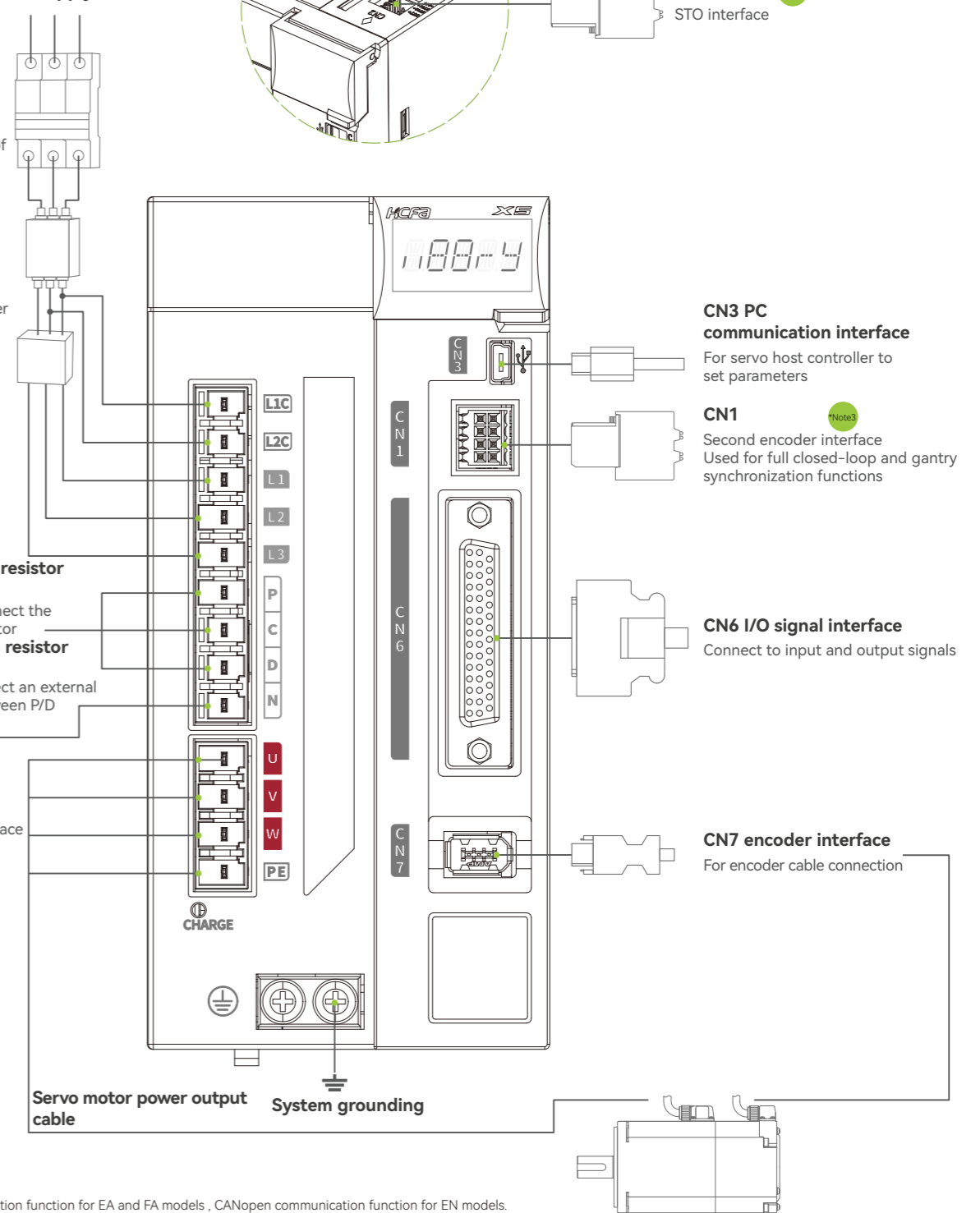

CN4/CN5 communication interface
Used for RS485 communication, or CANopen communication

CN2 STO interface

CN3 PC communication interface
For servo host controller to set parameters

CN1 Second encoder interface
Used for full closed-loop and gantry synchronization functions

CN6 I/O signal interface
Connect to input and output signals

CN7 encoder interface
For encoder cable connection

Servo motor power output cable

System grounding

*1: 485 communication function for EA and FA models, CANopen communication function for EN models.

*2: Only supported by FA full-function models.

*3: Only supported by FA full-function models.

*4: For DC bus use, please do not connect the neutral line of the power supply.

Models of 100W-1KW



Circuit breaker

Used to protect the power supply circuit and cut off the power supply in case of overcurrent.

Noise filter

Used to suppress noise from the power supply.

Magnetic contactor

Turn on/off the servo power supply. Please install surge absorber when using.

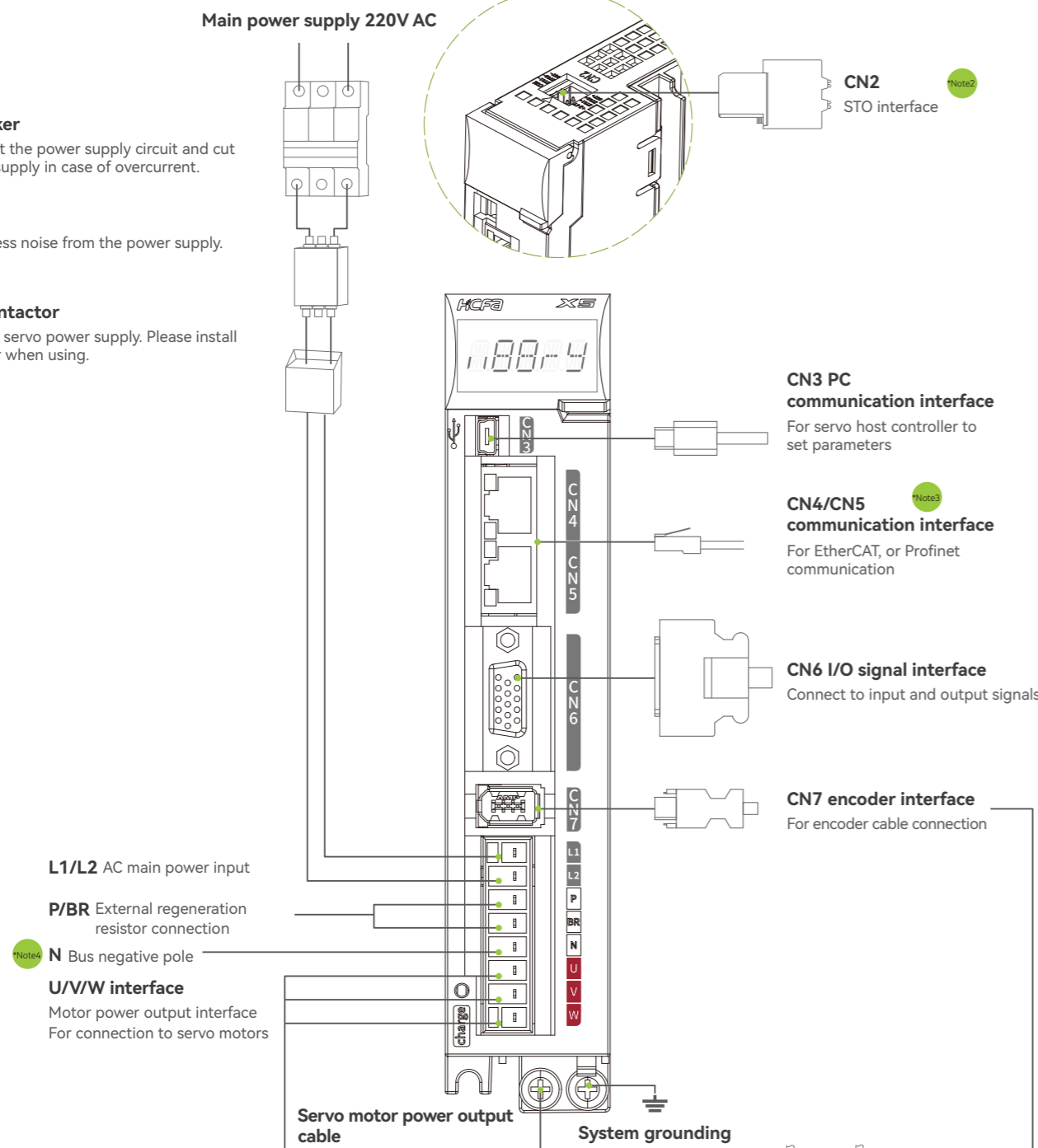

CN2 connector	No.	Signal name	Description
	1	STO_OUT+	Output+
	2	STO_OUT-	Output-
	3	STO2+	Input2+
	4	STO2-	Input2-
	5	STO1+	Input1+
	6	STO1-	Input1-
	7	24V	Internal 24V port
	8	COM	

Models of 1.5KW-2.5KW



Circuit breaker

Used to protect the power supply circuit and cut off the power supply in case of overcurrent.

Noise filter

Used to suppress noise from the power supply.

Magnetic contactor

Turn on/off the servo power supply. Please install surge absorber when using.

L1C/L2C

AC control power input

L1/L2/L3

AC main power input

Internal regeneration resistor interface (P/C)

Short-circuit P/C and connect the built-in regenerative resistor

External regeneration resistor interface (P/D)

Disconnect P/C and connect an external regenerative resistor between P/D

N Bus negative pole

^{Note4}

U/V/W interface

Motor power output interface
For connection to servo motors

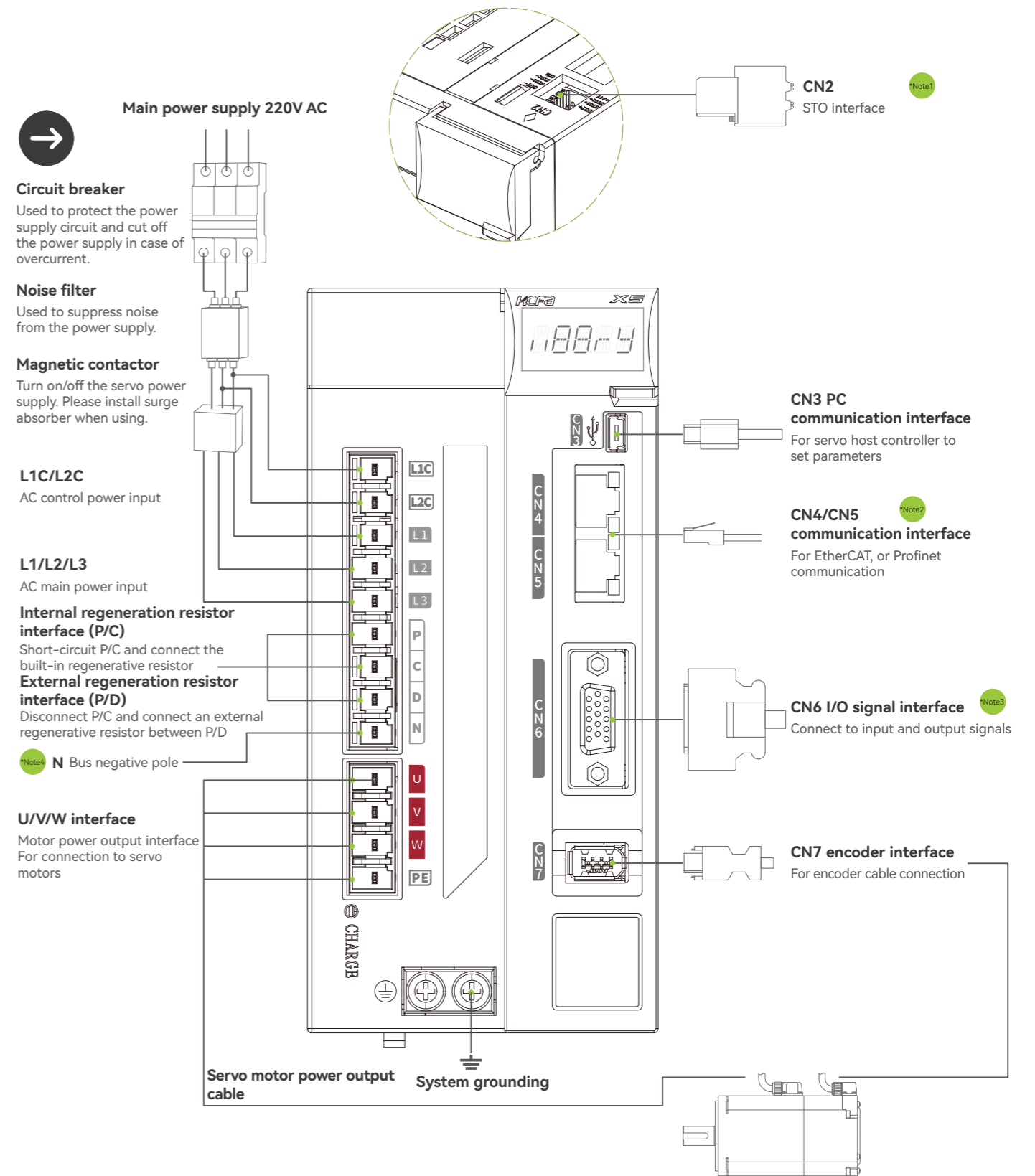

^{Note1} *1: EtherCAT communication function for EB and FB models, Profinet communication function for FR models.
^{Note2} *2: Only supported by FB and FR full-function models.
^{Note4} *4: For DC bus use, please do not connect the neutral line of the power supply.

Models of 2KW-7.5KW

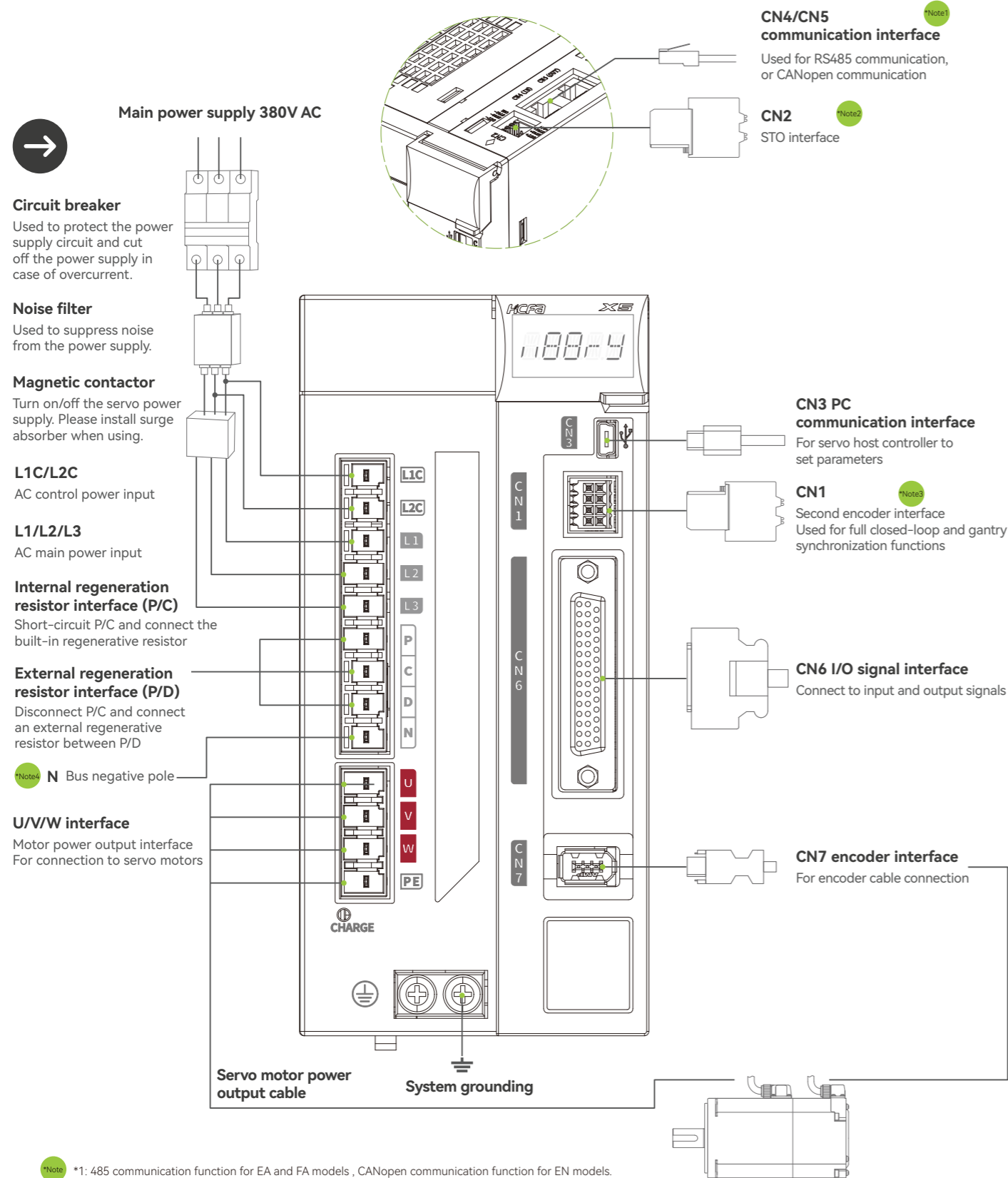

Models of 2KW-7.5KW

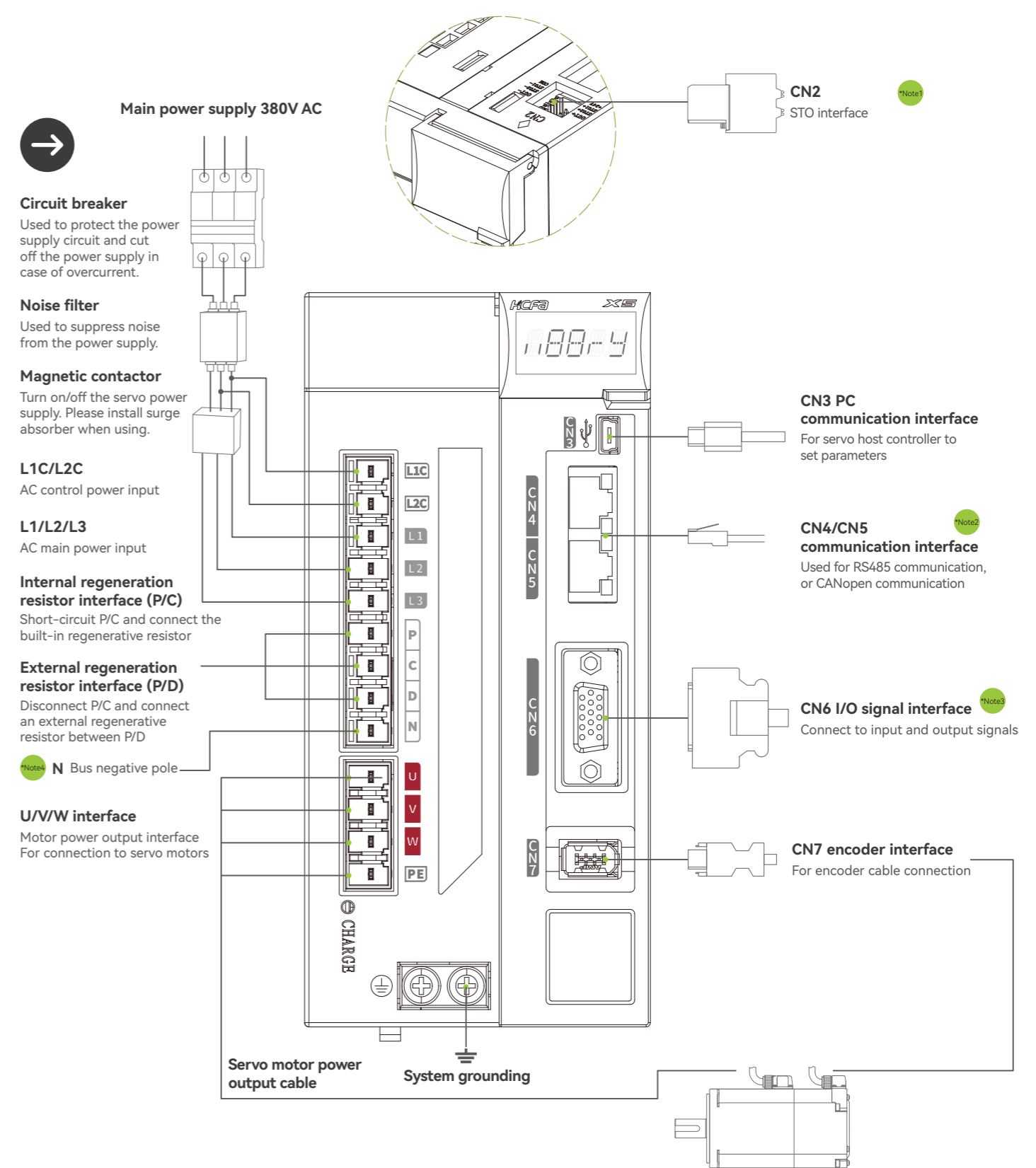

*Note1: 485 communication function for EA and FA models, CANopen communication function for EN models.

*Note2: Only supported by FA full-function models.

*Note3: Only supported by FA full-function models.

*Note4: For DC bus use, please do not connect the neutral line of the power supply.

*Note1: EtherCAT communication function for EB and FB models, Profinet communication function for FR models.

*Note2: Only supported by FB and FR full-function models.

*Note4: For DC bus use, please do not connect the neutral line of the power supply.

EA/FA pulse and EN CANopen

100W/400W External dimension(mm)

Weight: 0.75KG

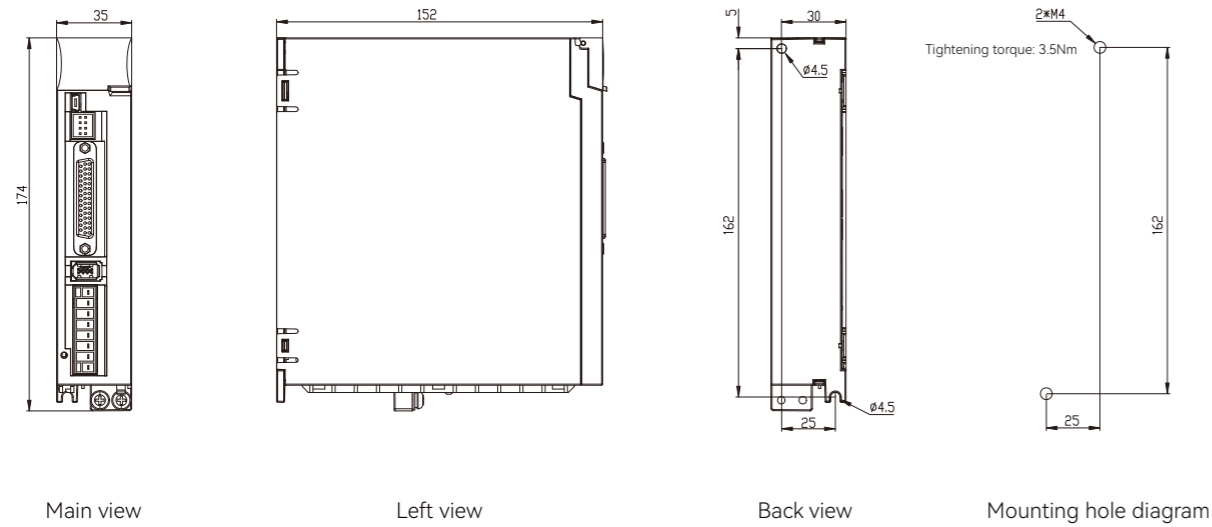

EB/FB EtherCAT and FR Profinet

1.5KW/2.0KW/2.5KW/3KW External dimension(mm)

Weight: 1.75KG

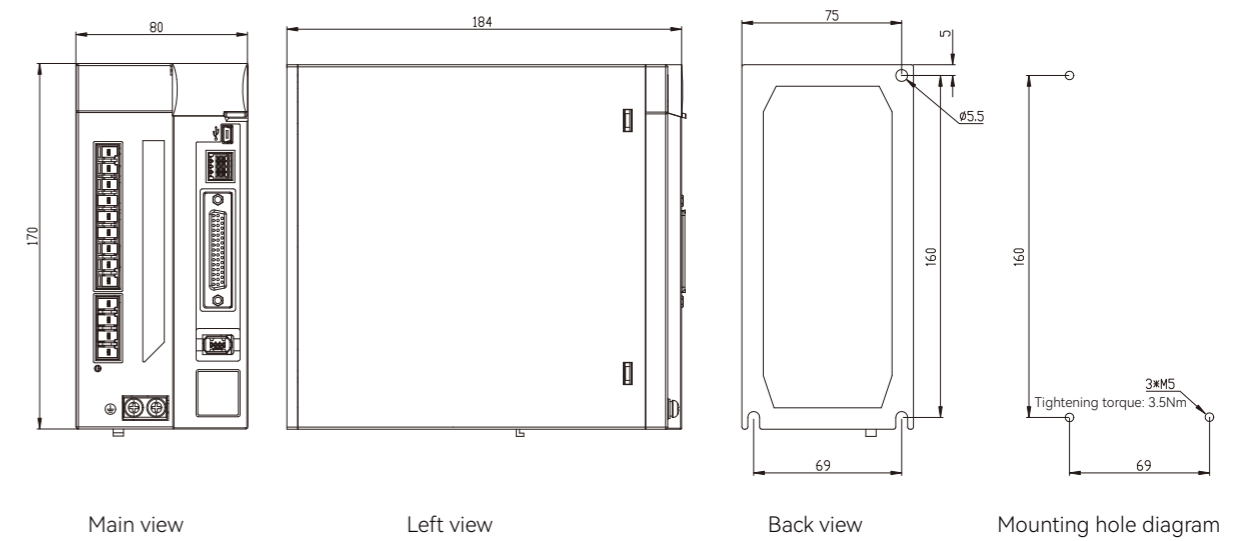

750W/1KW External dimension(mm)

Weight: 1.1KG

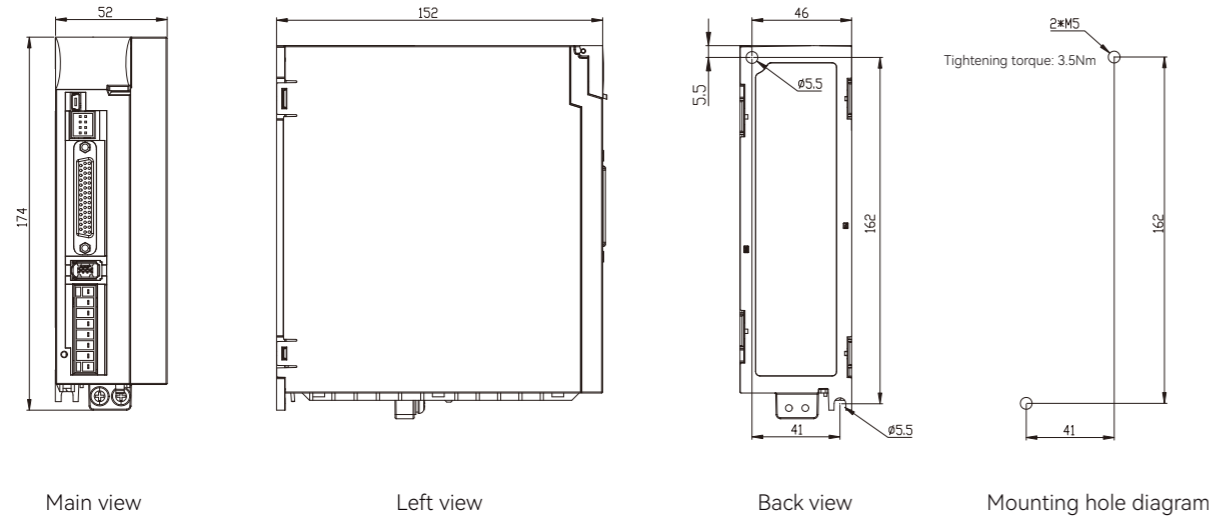

5KW/7.5KW External dimension(mm)

Weight: 2.3KG

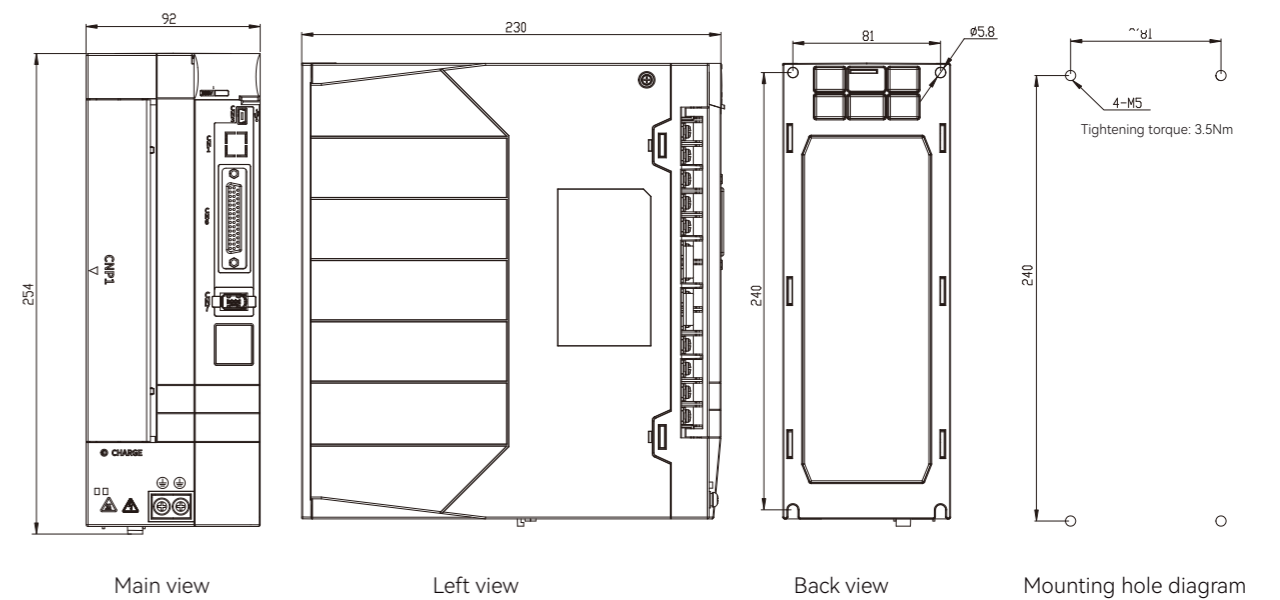

Empowering Industry, Shaping Smart Manufacturing

We not only provide essential components for industrial automation, but also engage in industrial robots, industrial machinery, and digital factories. We can offer businesses comprehensive solutions integrating **automation, intelligent equipment, and digitalization.**

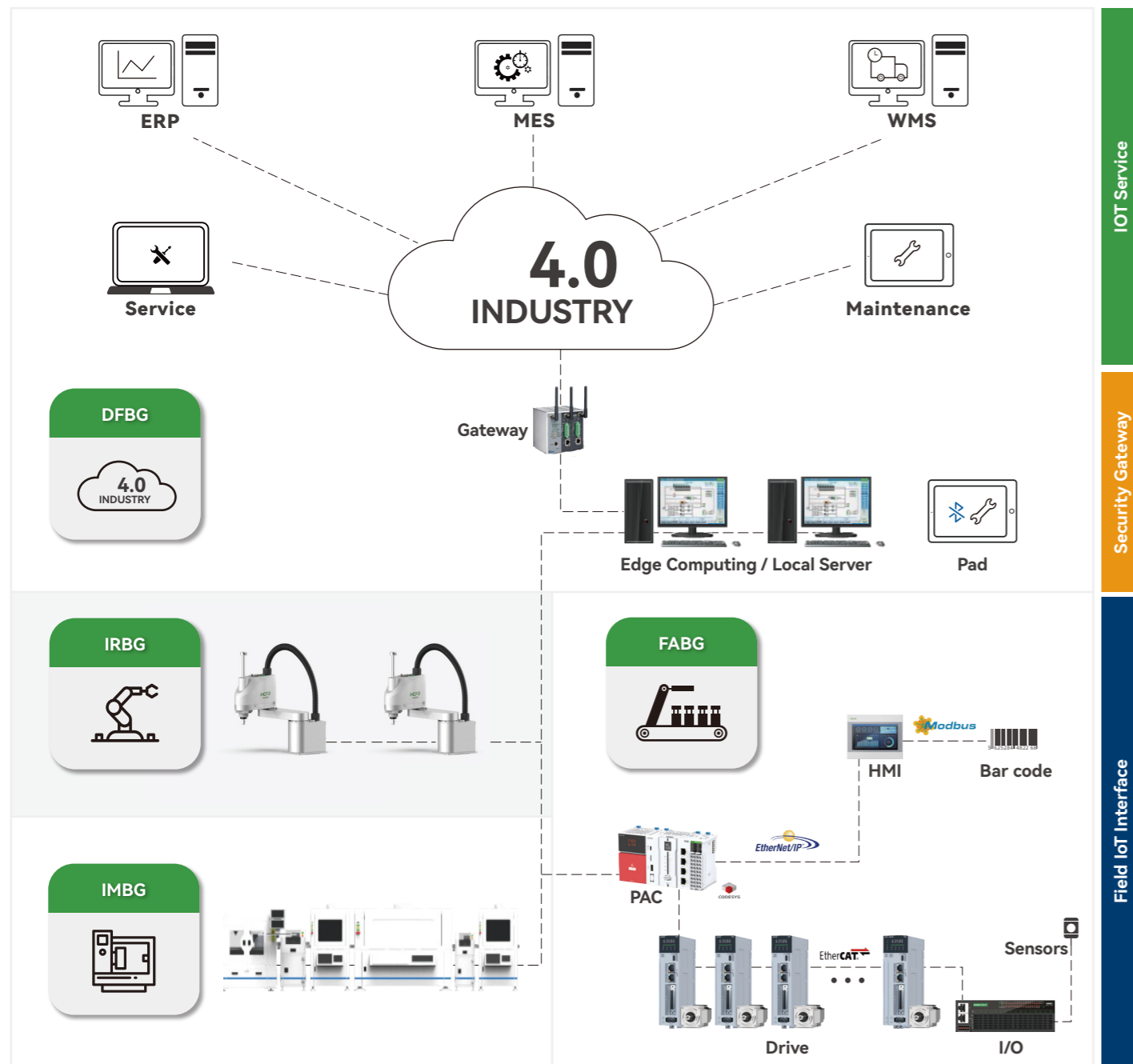

Delivering Core Components & Solutions as the Essential Partner

Zhejiang Hechuan Technology Co., Ltd. (HCFA Technology), founded in 2011, is a company dedicated to developing, manufacturing, sales, and application-integration of industrial automation products. It is committed to supplying core components and system-integration solutions for smart factories.

Its product range encompasses controllers, servo systems, vision systems, encoders, variable-frequency drives (VFDs), human-machine interfaces (HMIs), electric rollers, and precision transmission components, covering the entire spectrum of the industrial automation field.

In November 2023, HCFA Technology and Bosch Rexroth inked a strategic cooperation agreement. Bosch Rexroth made a strategic investment in HCFA Technology and planned to collaborate on establishing a subsidiary. Grounded in shared innovative concepts and forward-thinking, the two parties will pool their respective strengths, create resource complementarity, and engage in in-depth cooperation, aiming to become ecological partners throughout the industrial automation value chain and drive the further advancement of China's industrial automation industry.

Stock Code: 688320

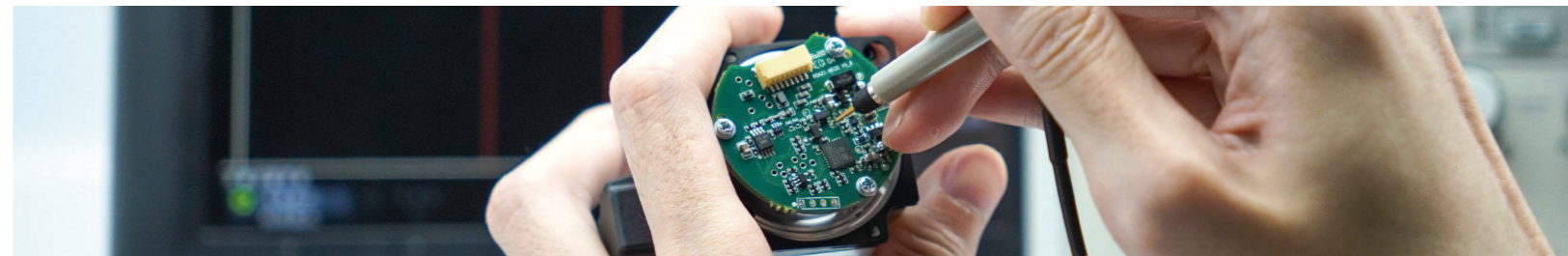

R&D Center

6

Number of Establishments

R&D Investment

10%+

Proportion of Revenue

R&D Personnel

300+

Elite Talent Pool

- Six R&D centers across Longyou, Hangzhou, Shenzhen, Dalian, Suzhou, and Germany
- Independently designed ASIC & SOC chips for domestic fabrication and localization substitution
- Industry-leading AMR magnetic technology and high-precision encoders